

2008

Teacher's Autonomy Support and ESL Classroom Engagement: The Road Less Traveled

Rajaletchumi Thaliah
Universiti Utara Malaysia

Rosna Awang Hashim
Universiti Utara Malaysia

Originally published in the Proceedings of the EDU-COM 2008 International Conference. Sustainability in Higher Education: Directions for Change, Edith Cowan University, Perth Western Australia, 19-21 November 2008.

This Conference Proceeding is posted at Research Online.

<http://ro.ecu.edu.au/ceducom/50>

Thaliah, R. and Hashim, R.A., Universiti Utara Malaysia, Malaysia
Teacher's Autonomy Support and ESL Classroom Engagement:
The Road Less Traveled

Rajaletchumi Thaliah¹ and Rosna Awang Hashim²

¹Universiti Utara Malaysia

²Universiti Utara Malaysia

ABSTRACT

This study investigated the construct of Teacher Autonomy Support Scale (TASS) in the context of ESL classroom in Malaysia and how it influenced student's classroom engagement. The sample comprised 378 students from 14 day schools in a rural area. An empirical study (N=378) was conducted to explore aspects of reliability and validity of the TASS. Confirmatory Factor Analysis via AMOS (7.0) showed evidence of convergent validity of the newly developed scale. A covariance structural analysis shows that teacher's autonomy support is a significant predictor for cognitive and behavioural engagement for students in ESL classroom.

Keywords: Teacher autonomy support- cognitive engagement – behavioural engagement

INTRODUCTION

Understanding of engagement in classroom is essential for teachers to sustain positive learning outcomes from students. Pre-service teachers' who are produced and trained by higher institution need to have an understanding of predictors which will make their students engage in the process of teaching and learning as to become better classroom managers. Trained teachers displayed significantly more autonomy supportive behaviours than did non-trained teachers based on the study done by Reeve, Jang, Carrell & Bach (2004) so these understandings will ensure the sustainability of academic achievement and prevents disengagement that leads to negative learning outcomes. Success in school depends on the extent to which students engage adaptively in classroom learning tasks (Patrick, Ryan & Kaplan, 2007). Classroom engagement is an important factor to predict sustainability of adolescents in schooling process. It is seen as antidote to low achievement, high levels of student's boredom and disaffection (Fredricks, Blemenfled, Friedel & Paris, 2003). Johnson, Kirkpatrick, Crosnoe & Elder (2001) pointed out that few studies have systematically analysed the determinants of different engagement measures especially in developing countries. One way is by providing autonomous motivation where students experience autonomy that makes students take charge of their own learning. The opposite of autonomy support is controlling. The tendency towards a controlling motivating style is an unfortunate state of affairs in light of self-determination theory's research which shows that an autonomy-supportive motivating style is more strongly associated with positive outcomes than controlling style (Ryan & Deci, 2000, 2002)

LITERATURE REVIEW

Autonomy- Supportive Teaching

There are many factors that contribute to students' interest and level of engagement in learning, and teachers have little control over many of those factors (Lumsden, 1994). However, research has shown that teachers can influence student's motivation (Pajares, 1992). Thus, to promote an interest in learning, a valuing of education, and an affirmation of personal capabilities, teachers need to find ways to support students' engagement. Types of autonomy support need to be identified so that teachers know what to say and do to support students' engagement where this can influence students' attitudes

about their capabilities and their interpretation of success and failure that affect their willingness to engage themselves in learning (Anderman & Midgley, 1998). Teachers motivate students using interpersonal styles that range from highly controlling to highly autonomy supportive (Reeve, 1998). Self-determination theory identifies that motivating style is partly a matter of personality (Deci, 1995; Deci & Ryan, 1991). Deci (1995) reasons that autonomy support is a personal orientation that influences interaction. In the interaction there are skills acquired by teacher to support the autonomy of others such as taking other person's perspectives, acknowledging feelings and making information available for decision making.

Little is known on what kind of motivating styles held by our ESL teachers. A study conducted in Malaysia by Tunku Mohaini and Marohaini Yusoff found that English teachers need to encourage students' participation and the role of teacher was emphasized. Another study was also carried out by Supyan Hussin, Nooreiny Maarof & J.V.D'Cruz (2005) in finding out teacher's attitude towards teaching English Language among 77 teachers in a workshop conducted in Maran District, Pahang. In their observation, it was reported that, teachers tended to ignore the importance of positive self-concept, high self-esteem, positive attitude, clear understanding of the goals for language learning and continuous active participation in the language learning process. Based on these two local studies it has been emphasized that the role of ESL teacher in motivating students is still not satisfactory but did not relate the type of style adopted by English teachers. Almost all previous studies on teachers motivating style were self-reported by teachers but in this study students perceived their English teacher's motivating style. The current research looks at the types of autonomy supportive motivating styles undertaken by Malaysian ESL teachers and how these supports influences students classroom engagement. Teacher autonomy support is examined by identifying the types of support derived from focus group interviews.

Engagement

Engagement according to Newmann's (1992, p. 12) is "... the student's psychological investment in and effort directed toward learning, understanding, or mastering the knowledge, skills, or crafts that academic work is intended to promote." A number of developmental study showed that there is a decline in student's engagement as the students progress through school (Jacobs, 2002; Stipek and Mac Iver, 1989). Therefore, it is a great concern to motivate students' throughout their learning, especially in the classroom context.

In the field of second language motivation, learners motivation to learn can be enhanced by language teachers who can determine every facet of classroom life (Dornyei, 2007 & Ushioda, 2003). Two types of engagement which are essential in classroom settings which are behavioural and cognitive engagement. Factors that indicate behavioural engagement are student's effort, attention, persistence during the initiation and execution of learning activities (Skinner & Belmont, 1993). In school settings, engagement is important because it functions as a behavioural pathway by which students' motivational processes contribute to their subsequent learning and development (Reeve et al., 2004)

DEVELOPMENT OF HYPOTHESES

The purpose of the present investigation was to identify the components of Teacher Autonomy Support and to examine the psychometric properties of TASS and its relation with ESL classroom engagement. It was hypothesized that subscales of TASS and classroom engagement would show convergent validity (H₁). Previous research done by Rosna Awang Hashim et al. (2006) has demonstrated that school engagement comprised behavioural, cognitive and psychological engagement with second order factor. In this study it was hypothesized that classroom engagement could be explained by a second order factor of behavioural engagement (H₂) and cognitive engagement (H₃). Finally it is hypothesized that Teacher Autonomy Support is significantly related to classroom engagement (H₄).

METHOD

This study utilizes focus group interview and a survey method. The survey method involves the gathering of cross-sectional data to investigate the roles of teacher autonomy support and classroom engagement among L2 learners.

Participants

The unit of analysis for this study are adolescents of 16 years old in Perlis, the smallest state in Malaysia. The survey sample consists of 378 students from 14 day schools in this state where samples consist of 52.6 % (N=199) boys and 47.4% (N=179) girls. Initially fifty students took part in five focus group interviews prior to survey data collection.

Procedures

In order to gather initial data because there is little information on types of autonomy support adopted by Malaysian ESL teachers, five focus group interviews were conducted. Fifty students reflecting different abilities of proficiency in English Language took part in the interview. All the five groups consisted of 8-12 students. An interview protocol guided focus group discussions to answer research questions. Data analysis was done based on the transcriptions, where dimensions were identified by extracting the descriptors. Items were constructed and developed accordingly. In designing the instrument, phrases and wordings found in the interview transcripts were retained as much as possible. Pilot testing was done to revise items in order it will be more comprehensible. The newly developed questionnaire was administered during English lessons so that there will be a better perception of their English teachers.

Measures

The questionnaire comprises 42 items, divided into 2 sections. The first section measures teacher autonomy support which is a new instrument and the second section measures classroom engagement.

Teacher Autonomy Support

In order to cover the breadth of the content, and also keep the instrument at a reasonable length, only five items were constructed for each dimension. This was also attempted due to provide a multi-faceted picture of teacher's support in ESL classroom without becoming too narrow or specific by being a single item measured. An autonomy supportive teacher nurture and increase students inner endorsement of their classroom activity (Reeve, 2006) where in this research, for dimensions of teacher autonomy support were derived as , teachers who are responsible in their duty, being friendly, show respect and encourage confidence in their students are dimensions of autonomy supportive teachers. Exploratory and confirmatory factor analyses procedures were used to examine the underlying hypothesized factor structure of TASS. The individual items were used as measured or observed variables to define its respective latent variables.

Classroom Engagement

The second section, classroom engagement comprises cognitive engagement (11 items) and behavioural engagement (10 items) which were adapted from Rosna Awang Hashim et al.(2006) Behavioural engagement scale was used to check students involvement in learning tasks, effort, persistence, attention, class participation and positive conduct. Cognitive engagement subsumes under meta-cognition which is defined as the conscious and periodic self-checking of whether one's goal is achieved and, when necessary, selecting and applying different strategies of planning, monitoring and regulating (Pintrinch & DeGroot. 1990). All items are measured using a five-point rating scale type of response ranging from 1= "almost never" to 5= "usually".

Classroom engagement items are analysed in parcels instead of individually. Use of item parceling in SEM is a common practice (Bandolas, 2002; Bandolas & Finney, 2001) because it results in fewer parameter estimations which can create a more optimal variable to sample size ratio (Bogazzi & Edwards, 1998). Therefore, in order to achieve greater stability in parameter estimates, the items for each engagement are bundled into 2 and three item parcels. This results in 9 item parcels or also known as indicators, which are more manageable and thus, reduces problems in convergence when using individual items (Little, Cunningham, Shahar & Widaman, 2002)

RESULTS

Data analyses were designed to answer 4 hypotheses. Descriptive statistics will reveal internal consistency of all the variables while confirmatory factor analysis and a structural model was conducted to test the fitness of data.

Intercorrelations and Reliability

Table 1: Means, Standard Deviations, Internal Consistencies and Intercorrelations, of the variables under investigations.

	M	SD	Cronbach's Alpha	1	2	3	4	5	6
1. Being Responsible	3.90	0.64	.64	—					
2. Being Friendly	3.87	0.72	.77	.461**	—				
3. Showing Respect	4.10	0.80	.82	.552**	.66**	—			
4. Encourage Confidence	3.69	0.69	.62	.487**	.49**	.54**	—		
5. Cognitive Engagement	3.35	0.60	.82	.13**	.19**	.29**	.28**	—	
6. Behavioural Engagement	3.86	0.71	.80	.25**	.28**	.57**	.28**	.57**	—

Table 1 summarizes means, standard deviations, reliabilities and intercorrelations estimates (Cronbach's α values), and intercorrelations. All 4 subscales of TAS showed good levels of internal consistency (i.e., $.64 < \alpha < .80$).

Convergent Validity

Convergent validity was assessed by examining whether the factor loadings of most indicators related to the same underlying construct are significantly different from zero (Anderson & Gerbing, 1988). Convergent validity is evident when all indicators loaded on one common factor hypothesized earlier. In this study, all indicators for TAS loaded on their corresponding constructs which can be summarized by Figure 1.

Figure 1 : A second order measurement model for Teacher Autonomy Support
 Chi-square=116.655, df=52, Ratio=2.243
 NFI=.920, TLI=.941, CFI=.953, Rmse=.057

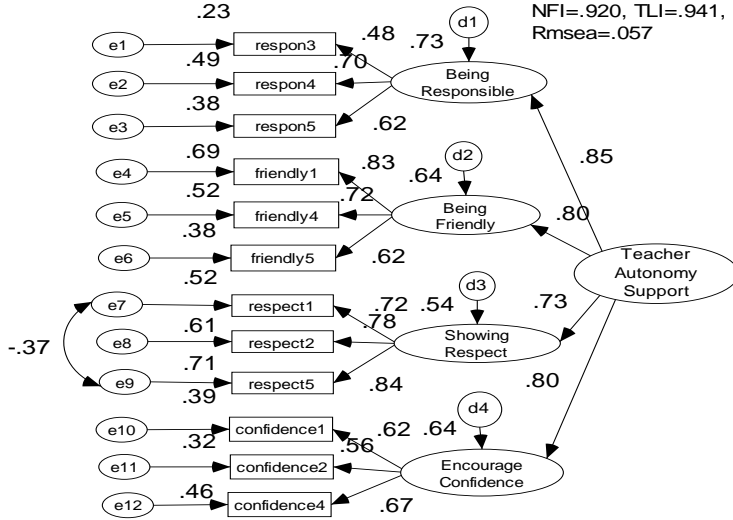

Confirmatory factor analysis confirmed evidence of convergent validity of TAS(H₁)
 Path coefficients of all the four dimensions ranged from .73 to .85, indicating that they are interrelated and form a latent construct of teacher autonomy support.

Figure 2 :
 Results of the measurement model for classroom engagement
 Chi-square=46.268, df=24, Ratio=1.928
 NFI=.959, CFI=.980, TLI=.970, Rmse=.050

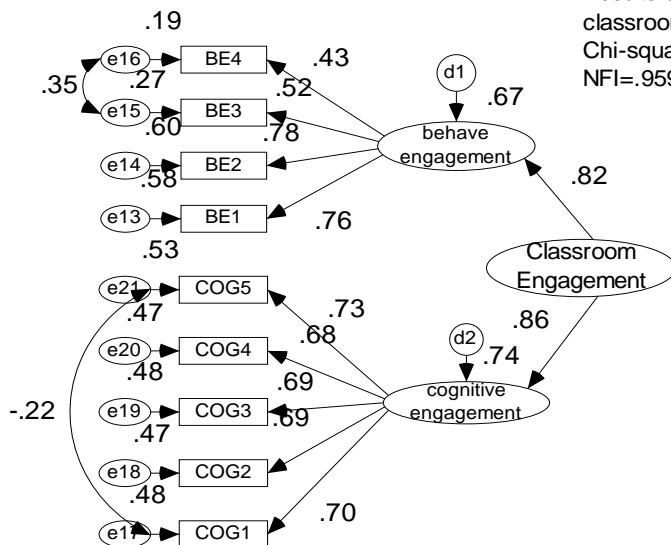

Inspection of modification indices suggested that we should let errors of e15 and e16 correlate. These two item parcels share similar properties of skipping classes and disruptive behaviours in ESL classroom. E17 and e21 share similar properties on surface strategy in handling English language. The measurement model on classroom engagement revealed that classroom engagement can be explained by behavioural and cognitive engagement. The path coefficients for each engagement in the hierarchical model were .82 and .86. Thus, provide evidence for Hypothesis 2 and Hypothesis 3.

Structural Model

A structural equation analysis was performed through the use of AMOS 7.0(Arbuckle,2007). The standardized estimates are reported for ease in interpreting model parameters. Model fit was established by examining a combination of absolute and incremental fit statistics. Absolute fit statistics used in this study included the traditional chi-square/degree of freedom ratio (χ^2/df), and the root mean square error of approximation (RMSEA: Steiger,1990). Incremental fit statistics were also chosen for their ability to evaluate different aspects of model fit. The three incremental fit statistics chosen were the Normed Fit Index (NFI: Bentler and Bonnett, 1980), Tucker Lewis Index (TLI: Tucker & Lewis,1973) and the Comparative Fit Index (CFI:Bentler, 1989). For the chi-square tests, a significant value relative to the degrees of freedom indicates that the model does adequately fit the data. Thus, a good fitting model is indicated by non-significant results from these tests. However since chi-square is sensitive to sample size we also rely on other goodness of fit indices. The NFI,TLI and CFI vary along a 0 to 1 continuum. Values greater than .90 and .95 reflected an acceptable and excellent fits to the data, respectively. Finally, the RMSEA values at or less than .05 and .08 reflect a close and reasonable fit respectively (Schumacker & Lomax ,1996).

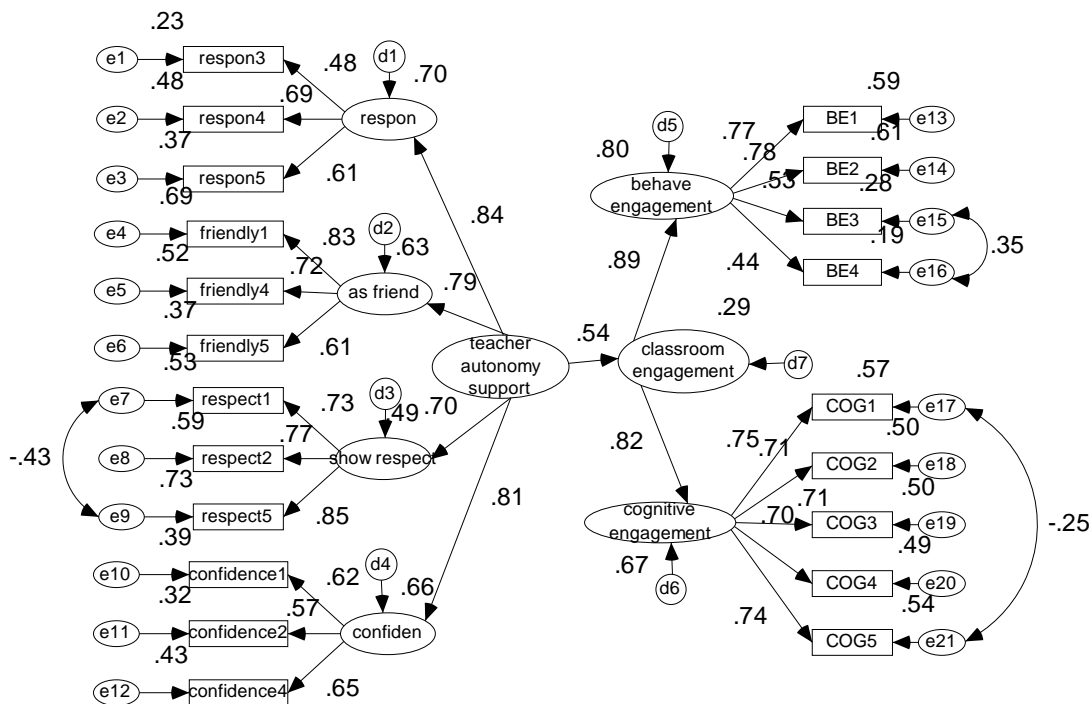

Figure 3 :Results of the hypothesized model
Chi-square=321.115, df=184, Ratio=1.745
NFI=.885, CFI=.947, TLI=.939, Rmse=.044

The overall χ^2 value was 343.638, with 186 *df*. The chi-square test is sensitive to sample size and its value must be assessed in relation to their degree of freedom, with a $\chi^2 /df \leq 3$ which is generally recognized as good fit of the model to the data where in this study it is 1.848. Root mean square error of approximation (RMSEA) =.047, where according to Browne & Cudeck, (1989) a close fit of the model is at .05 and less. Normed fit index (NFI) =0.876, comparative fit index = .939, Tucker-Lewis Index (TLI)=.931. Values greater than .90 reflected an acceptable fit to the data. Model fit was established by examining a combination of absolute and incremental fit statistics. The results of the structural model showed that the model as a whole explained 29% of the variance in classroom engagement. The explained variance in behavioural engagement and cognitive engagement was 80% and 67% respectively. In Figure 3 teacher's autonomy support ($\beta = .53$, $t = 6.3$, $p < .05$) has a significant positive direct impact on ESL students' classroom engagement. There were statistically significant path coefficients indicating that teacher's autonomy support comprises of all the four types

of being responsible, being friendly, showing respect and encouraging confidence and directly influence classroom engagement which comprises behavioural and cognitive engagement which provide evidence for Hypothesis 4.

DISCUSSION

The purpose of this study was to develop TASS and examine the latent structure of teacher autonomy support, and assess a model of its relationship with classroom engagement. The TASS questionnaire was developed to measure four dimensions of teacher autonomy support which are being responsible, being friendly, showing respect and to encourage confidence. This study provides evidence of convergent validity of the newly developed TASS. Teacher autonomy support scale in this study is a validated instrument in Malaysian context which can proceed to investigate in greater detail the relationship between teacher autonomy support and other learning outcomes. In this study teacher autonomy support was conceptualized in four dimensions represented by three indicators each. The finding concerning a positive association between autonomy supportive teaching and students engagement is consistent with the results obtained by Reeve et al. (2004). Comparing this research to the one done by Reeve & Jang (2006) where they investigated teacher autonomy support instructional behaviours and identified it with students' perception of autonomy there are some similarity and differences. Showing respect and encouraging confidence is similar with the items of encouraging students' effort and acknowledging students' perspective and experience. The dimension of being responsible and being friendly which means, English teachers' carry out their duties and being approachable by students were newly identified in Malaysian context. Being a country that upholds eastern values of showing high respect to teachers, talking to them as friends is valued as nurturing and facilitating their engagement in ESL classroom. English teachers' carrying out their duties as required without neglecting their responsibility promotes engagement in learning among Malaysian ESL learners behaviourally and cognitively.

In rural Malaysian setting where students lack of resources at home in learning English, school plays a pivotal role in enhancing learning. Engagement in school is an important academic outcome in its own right and it serve as an important social signal whether students were motivated or disaffected over time (Furrer & Skinner, 2003). Autonomy supportive climate provided by teachers is considered as a critical motivational variable that predicted students' intention to persist in high school (Hardre & Reeve, 2003). Learning a second language and to sustain interest in language learning, especially for rural students' where their social environment do not give much support for second language acquisition, depend very much to their language teachers. Finally, teacher autonomy support not only show a direction and change but alleviate the growing problems of disinterested learners in classroom.

REFERENCES

- Anderman, L.H., & Midgley, C. ERIC digest (1998). Motivation and middle school students . Champaign, IL: ERIC Clearinghouse on Elementary and Early Childhood Education: ERIC Document Reproduction Service No.ED 421 281.
- Anderson, J. C.,& Gerbing, D. W. (1984). The effect of sampling error on convergence, improper solutions, and goodness-of-fit indices for maximum likelihood confirmatory factor analysis. *Psychometrika*,49, 155–173.
- Arbuckle, J.L.(2007).AMOS 7.0 (Computer Software). Chicago: Smallwaters.
- Bandalos, D.L.(2002). The effects of item parceling on goodness-of-fit and parameter estimate bias in structural equation modelling. *Structural Equation Modeling*, 9, 78-102

- Bentler, P.M. (1990). Comparative fit indexes in structural models. *Psychological Bulletin*, 107(234-246)
- Browne, M.W. & Cudeck, R. (1993), Alternative ways of assessing model fit. In Bollen, K.A. & Long, J.S. (Eds.) *Testing Structural Equation Models*. pp.136-162. Beverly Hills, CA: Sage.
- Crowley, S.L. & Fan, X. (1997). 'Structural equation modelling: Basic concepts and applications in personality assessment research', *Journal of Personality Assessment*, 68, 508-539.
- Deci, E. L., & Ryan, R. M. (1995). Human autonomy: The basis for true self-esteem. In M. Kernis (Ed.), *Efficacy, agency, and self-esteem* (pp.31-49). New York: Plenum Press.
- Deci, E.L. & Ryan, R.M. (1991). A motivational approach to self: Integration in personality. In R. Dienstbier (Ed.), *Nebraska symposium on motivation*, Vol 38: Perspectives on motivation (pp. 237-288). Lincoln: University of Nebraska Press.
- Dörnyei, Z. (2007). Creating a motivating classroom environment. In J. Cummins & C. Davison (Eds.), *International handbook of English language teaching* (Vol. 2, pp. 719-731). New York: Springer.
- Guay, F., Boggiano A. K. and Vallerand R.J. (2001) Autonomy Support, Intrinsic Motivation, and Perceived Competence: Conceptual and Empirical Linkages. *Personality and Social Psychology Bulletin*
- Hardre, P., & Reeve, J. (2003). A motivational model of rural students' intentions to persist in versus drop out of high school. *Journal of Educational Psychology*, 95, 347-356.
- Jacobs, Vicki A. (2002). Reading, Writing and Understanding. *Educational Leadership*, Vol.60, No.3, 58-61.
- Johnson, Kirkpatrick M., Crosnoe R. and Elder G.H, Jr. 2001. "Students' Attachment and Academic Engagement: The Role of Race and Ethnicity." *Sociology of Education* 74 (4): 318-340.
- Little, T. D., Cunningham, W. A., Shahar, G., & Widaman, K.F. (2002). To parcel or not to parcel: Exploring the question, weighing the merits. *Structural Equation Modelling: A Multidisciplinary Journal*, 9, 151-173.
- Lumsden, Linda. (1994). Student Motivation to Learn. *Emergency Librarian*, 22 (2) 31-32.
- Newmann, F. M. (Ed.). (1992). *Student engagement and achievement in American secondary schools*. New York: Teachers College Press.
- Patrick H., Ryan A., M., & Kaplan A. (2007) Early Adolescents' Perceptions of the Classroom Social Environment, Motivational Beliefs, and Engagement, *Journal of Educational Psychology*, Vol.99. No.1 .83-98.
- Pintrich, P. & DeGroot, E. V. (1990). Motivational and self-regulated learning components of classroom academic performance. *Journal of Educational Psychology*, 82(1), 33-40.
- Pelletier, L. G., Séguin-Levesque, C., & Legault, L. (2002). Pressure from above and pressure from below as determinants of teachers' motivation and teaching behaviours. *Journal of Educational Psychology*, 94, 186-196.

Reeve, J., Jang, H., Carrell, D., Jeon, S., & Barch, J. (2004). Enhancing students' engagement by increasing teachers' autonomy support. *Motivation and Emotion*, 28, 147-169.

Reeve, J. (1998). Autonomy support as an interpersonal motivating style: Is it teachable? *Contemporary Educational Psychology*, 23, 312-330.

Rosna Awang Hashim, Zahyah Hanafi, Azlina Murad Sani, Harshita Aini Haron, & Hamida Bee Bi Abdul Karim (2006). Social psychological determinants of adolescent school engagement. Research Report, Unpublished. Sintok : Universiti Utara Malaysia.

Ryan, R.M., & Deci, E. L. (2000). Self-determination theory and the facilitation of intrinsic motivation, social development, and well-being. *American Psychologist*, 55, 68–78.

Ryan, R. M., Connell, J. P., & Grolnick, W. S. (1992). When achievement is not intrinsically motivated: A theory and assessment of self-regulation in school. In A. K. Boggiano & T. S. Pittman (Eds.), *Achievement and motivation: A social-developmental perspective* (pp.167-188). New York: Cambridge University Press.

Ryan, R. M., & Deci, E. L. (2002). Overview of self-determination theory: An organismic dialectical perspective. In E. L. Deci & R. M. Ryan (Eds.), *Handbook of self-determination research* (pp.3–33). Rochester, NY: University of Rochester.

Shumacker, R.E., & Lomax, R.G. (1996). *A beginner's guide to structural equation modelling*. New Jersey : Lawrence Erlbaum Associates.

Skinner, E. A., & Belmont, M. J. (1993). Motivation in the classroom: Reciprocal effects of teacher behaviour and student engagement across the school year. *Journal of Educational Psychology*, 85, 571–581.

Steigner, J.H. (1990). Structural model evaluation and modification: An interval estimation approach. *Multivariate Behavioural Research*, 25, 173-180.

Stipek, D. J., & Mac Iver, D. (1989). Developmental change in children's assessment of intellectual competence. *Child Development*, 60, 521-538.

Supyan Hussin, Nooreiny Maarof, and J.V.D'Cruz,. Sustaining an Interest in Learning English and Increasing the Motivation to Learn English: An Enrichment Program. *The Internet TESL Journal*, Vol. VII, No. 5, May 2001 retrieved on 10 Sept. 2008 at <http://www.cie.ca/bachelor/library.html>

Tunku Mohani Tunku Mohtar & Marohaini Yusoff (1997). *The Language Teacher Sustaining Student Engagement In Classroom Discourse*. The Japan Association for Language Teaching. Volume 21, No.9, Sept.

Ushioda, E. (2003). Motivation as a socially mediated process. In D. Little, J. Ridley & E. Ushioda (Eds). *Learner autonomy in the foreign language classroom: Learner, teacher, curriculum and assessment* (pp.90-103). Dublin, Ireland: Authentik.

Tucker, L.R., & Lewis, C. (1973). A reliability coefficient for maximum likelihood factor analysis, *Psychometrika*, 38, 1-10.