

2011

# Tuning Fuzzy Systems to Achieve Economic Dispatch for Microgrids

Thair Mahmoud  
*Edith Cowan University*

Daryoush Habibi  
*Edith Cowan University*

Octavian Bass  
*Edith Cowan University*

Stefan W. Lachowicz  
*Edith Cowan University*

---

This article was originally published as: Mahmoud, T., Habibi, D., Bass, O., & Lachowicz, S. W. (2011). Tuning fuzzy systems to achieve economic dispatch for microgrids. Paper presented at the 2011 IEEE Innovative Smart Grid Technologies Asia. Perth, Australia. Original article available [here](#)  
© 2011 IEEE. Personal use of this material is permitted. Permission from IEEE must be obtained for all other uses, in any current or future media, including reprinting/republishing this material for advertising or promotional purposes, creating new collective works, for resale or redistribution to servers or lists, or reuse of any copyrighted component of this work in other works.

This Conference Proceeding is posted at Research Online.

<http://ro.ecu.edu.au/ecuworks2011/823>

# Tuning Fuzzy Systems to Achieve Economic Dispatch for Microgrids

T. S. Mahmoud *Member, IEEE*, D. Habibi, *Senior Member, IEEE*, O. Bass, *Senior Member, IEEE*, and S. Lachowicz, *Senior Member, IEEE*,

**Abstract**—In this paper, a Tuning Fuzzy System (TFS) is used to improve the energy demand forecasting for a medium-size microgrid. As a case study, the energy demand of the Joondalup Campus of Edith Cowan University (ECU) in Western Australia is modelled. The developed model is required to perform economic dispatch for the ECU microgrid in islanding mode. To achieve an active economic dispatch demand prediction model, actual load readings are considered. A fuzzy tuning mechanism is added to the prediction model to enhance the prediction accuracy based on actual load changes. The demand prediction is modelled by a Fuzzy Subtractive Clustering Method (FSCM) based Adaptive Neuro Fuzzy Inference System (ANFIS). Three years of historical load data which includes timing information is used to develop and verify the prediction model. The TFS is developed from the knowledge of the error between the actual and predicted demand values to tune the prediction output. The results show that the TFS can successfully tune the prediction values and reduce the error in the subsequent prediction iterations. Simulation results show that the proposed prediction model can be used for performing economic dispatch in the microgrid.

**Index Terms**—Demand Prediction, Economic Dispatch, Neuro Fuzzy Systems, Self Tuning Fuzzy Systems

## I. INTRODUCTION

**D**EMAND prediction plays an important role in many smart energy applications, including Energy Management Systems (EMS), generation scheduling, generators maintenance and energy trading. Smartgrid applications such as electronic energy markets and microgrids energy self-supply are highly dependent on the demand prediction. The planning of a distributed generation system uses demand prediction as a core in the planning process [1]. It is crucial therefor to have reliable demand prediction models to achieve secure generation scheduling and energy saving planning. The prediction of day-ahead load has been implemented using fuzzy systems based Mahalanobis Distance (MD) method [2]. The idea is to have the similar characteristic days for the operation historical data based on some independent data such as temperature and day order in the week. The hourly prediction of long term power demand was proposed using four year hourly load data from Turkish Electric Power Company [3]. This modelling technique was implemented as a nested three subsections of load prediction: yearly average demand, weekly residual demand variations within a year and hourly variation within a week. A new demand prediction method was presented to

enhance the demand modelling in the distributed applications. This modelling technique was applied based on two steps: state space model for the demand estimation and Artificial Neural Network (ANN) for short term prediction to cope with nonlinear change of the demand [4]. A short term prediction based on previous day features has been developed using ANFIS. Temperature, climate change, previous days load and its exit were used to predict the demand of every season [5]. ANFIS based on the data field was proposed to solve the drawbacks of the general fuzzy neural network and optimize fuzzy rules [6]. ANFIS was also used in next day demand forecasting to improve the power system as an application of ANN and fuzzy logic based hourly load demand with linear polynomial and exponential equation [?]. The time series modelling and ANFIS estimator were used to develop a demand prediction model [7]. Multivariate inputs for electrical load forecasting on hybrid neuro-fuzzy and fuzzy C-means forecaster were used to develop demand prediction model. The model was developed based on a neuro-fuzzy approach with additional fuzzy c-Means clustering method [8]. A new approach to short-term load forecasting in a deregulated and price-sensitive environment has been presented. A real-time pricing type scenario is envisioned where energy prices could change on an hourly basis with consumers having the ability to react to the price signal through shifting their electricity usage from expensive hours to other times when possible [9]. However, several parameters may significantly affect the accuracy of the demand prediction itself. The proposed demand modelling technique is used to develop a Generation Scheduling System (GSS). Fig 1 illustrates the concept of using demand prediction in GSS.

The automated generation scheduling will have a significant environmental and economic impact on the power generation. Generation scheduling problem has been solved by many approaches in the literature. Fuzzy optimization is proposed to solve the power systems generation scheduling problem [10]. A new approach to the fuzzy unit commitment problem using the absolutely stochastic simulated annealing method was proposed. The objective was to schedule the unit commitment fuzzy using a proper optimization algorithm [11]. The generation scheduling has been developed based on the electricity market environment. The work has presented a two level optimization model for optimal cost functions to be submitted by the producer to the system operators [12]. The paper presents a two-level optimization model that helps to

T. S. Mahmoud, D. Habibi, O. Bass and S. Lachowicz are with Edith Cowan University, Joondalup, WA 6027, AUSTRALIA (e-mail: t.mahmoud@ecu.edu.au) Telephone: +61 (8) 6304-5318, Fax: +61 (8) 6304-5811).

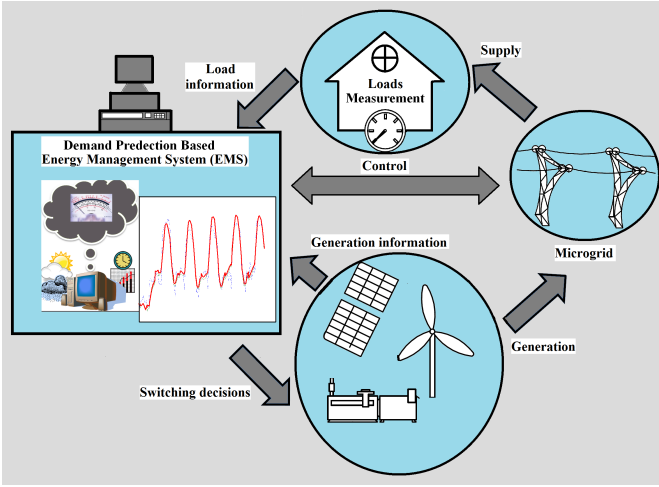

Figure 1. Simple Control Utilization of Demand Forecasting in SmartGrid

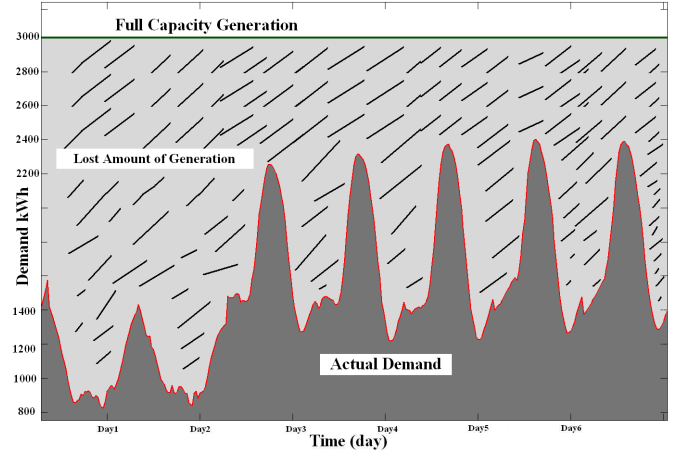

Figure 2. Energy generation for ECU microgrid

assign optimal cost functions to be submitted by the producer to the system operator. Optimal generation scheduling of a microgrid in islanding mode has been presented. Three steps for treating thermal unit commitment problem including the optimization of the renewable-thermal dispatch based on thermal unit commitment results has been presented [13].

Fuzzy-optimization approach has been proposed to plan wind and solar generation. This approach has considered the hourly load change, temperature and wind speed forecasting in generation scheduling [14]. Load modelling has been investigated to calculate the generation losses in the DGs planning [15]. It has been noted that having intelligent systems for economic dispatch has substantial benefits. This work will focus on the use of TFS in achieving economic dispatch for the microgrid case study. The proposed adaptive demand prediction technique will help develop the automated generation scheduling.

## II. ECONOMIC DISPATCH

Economic power generation is the art of minimizing the generation cost and transmission losses. Determining the needed energy for a specific load condition is called “*Economic Dispatch*”. In other words, it is the short-term determination of the optimal number of generation units. In this work, we aim at using the demand prediction to achieve the economic dispatch for the ECU microgrid. The main objective of our economic dispatch is to minimise the generation cost and mitigate  $CO_2$  emissions. The required amount of energy will be predicted every half hour in the ECU microgrid. Instead of supplying the full generation capacity to the microgrid in the islanding mode, a more optimized amount of generation will be supplied from the installed DGs, decided by the EMS based on the predicted load. Fig 2 shows the amount of lost energy from supplying the ECU microgrid from DGs with full generation capacity.

To achieve economic dispatch in ECU’s microgrid, the demand forecasting model is developed and simulated. The

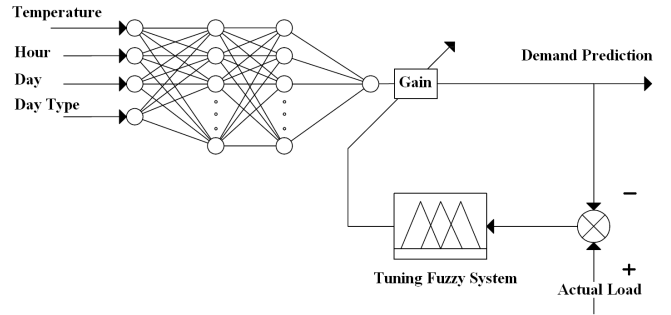

Figure 3. Tuning fuzzy prediction model

number of the needed DGs will be determined based on a priori half-an-hour prediction with a resolution of 0.5 MWh. To increase the life time of the DGs, rotational operation is planned for their usage.

## III. DESIGN METHODOLOGY

In this work, a TFS is added to the ECU energy demand model. It is proposed to tune the prediction model output to cope with the difference between the actual demand and the predicted demand. The basic structure of the proposed model is divided into two main sub-systems. First is the demand model, that is developed by supplying models historical operation data to the FSCM-based ANFIS. Second is the TFS, that is developed based on the knowledge of the difference between the predicted and actual demand values. Fig 3 shows the prediction adaptation strategy for the ECU energy demand.

The proposed prediction modelling details are explained in the following sections.

### A. Demand Model

Energy demand for the ECU microgrid has been modelled using an FSCM-based ANFIS. The demand prediction has been divided into twelve month prediction zones. Four input variables have been used to identify the demand prediction

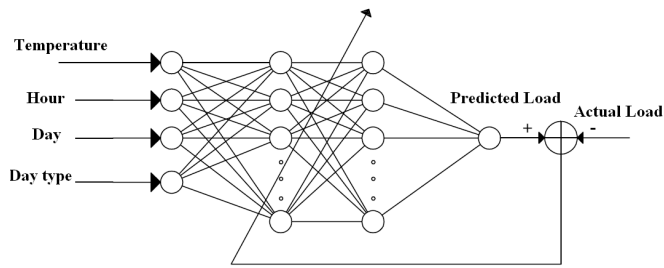

Figure 4. ANFIS demand prediction model

Table I  
ROI VALUES AND COMPLEXITY OF THE 12 MONTH MODELS

Months\Membership Functions ranges	ROI	Rules	Membership Fctn.
January	0.35	28	112
February	0.4	23	92
March	0.5	14	56
April	0.33	40	160
May	0.44	17	68
June	0.4	25	100
July	0.45	20	80
August	0.48	19	76
September	0.43	18	72
October	0.5	11	44
November	0.5	16	64
December	0.41	20	80

model for each month: temperature, hour, day and day type (work day, or non-work day). Cluster estimation and rules extraction have been applied on the historical load data to develop the Sugeno fuzzy inference system. Fig4 illustrates the used ANFIS modelling technique.

FSCM values selection may have strong effects on the complexity of the developed models. Table I shows the number of membership functions and the selected FSCM values for each of the twelve month models. After clustering is made, the developed membership functions are trained. Then, when the developed network is being trained, a simple test will be carried to verify the prediction accuracy of the developed models. When the test result is within an acceptable error bound, the modelling procedure is concluded. Figure 5 illustrates the developed membership functions January fuzzy prediction model inputs. It shows the range of inputs that covers January's operation in the ECU's campus to give the predicted demand at each data point. However, the other 11 months of the year have different range of inputs based on the pattern of operation and weather change along the four seasons of the year in city of Joondalup.

However, if the test result indicates a large error, the selection of the FSCM values and the number of the training epochs will be changed to try a new clustering and modelling step.

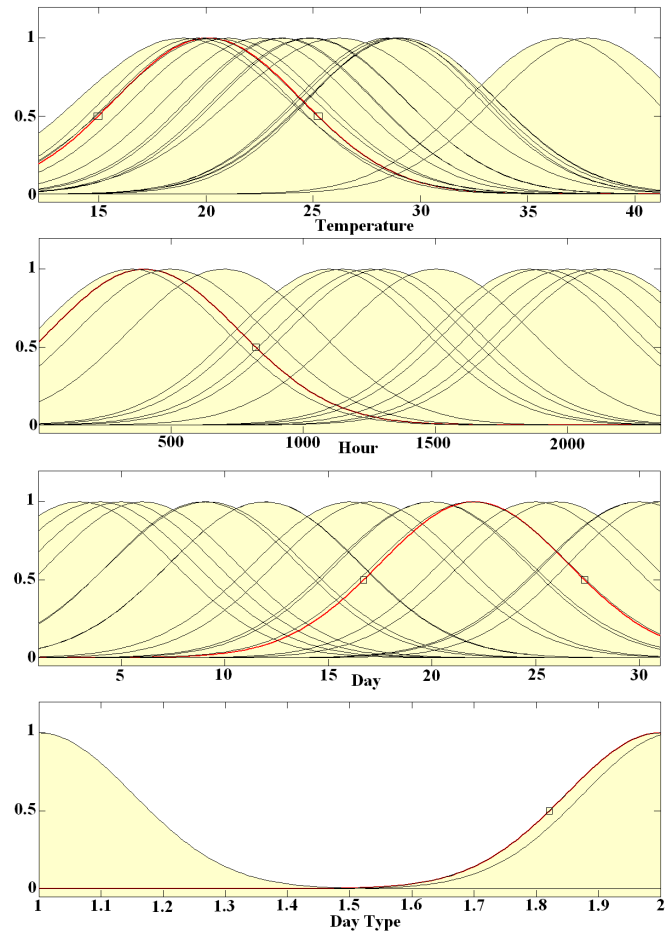

Figure 5. The developed input membership functions of January's energy prediction fuzzy model

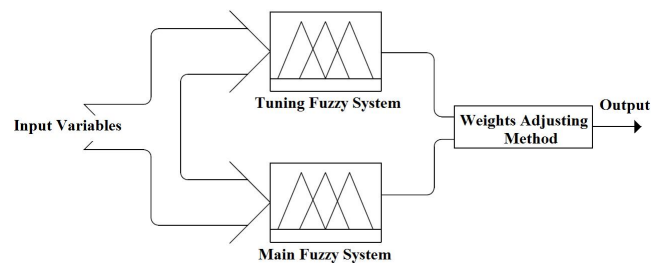

Figure 6. General tuning fuzzy system

### B. Tuning Fuzzy System

This section presents the design principles of the Tuning Fuzzy System (TFS). Generally, fuzzy rules are dependent on the control objectives and the type of the controller. To implement an adaptive (tunable) fuzzy system, three things have to be considered simultaneously: dynamic characteristics of a plant, self-selection of the performance index, and self-tuning of the controller parameters, respectively. A simple TFS operation structure is illustrated in Fig6.

Usually, the Weights Adjusting Method (WAM) is derived from the need of setting a specific weight for tuning the

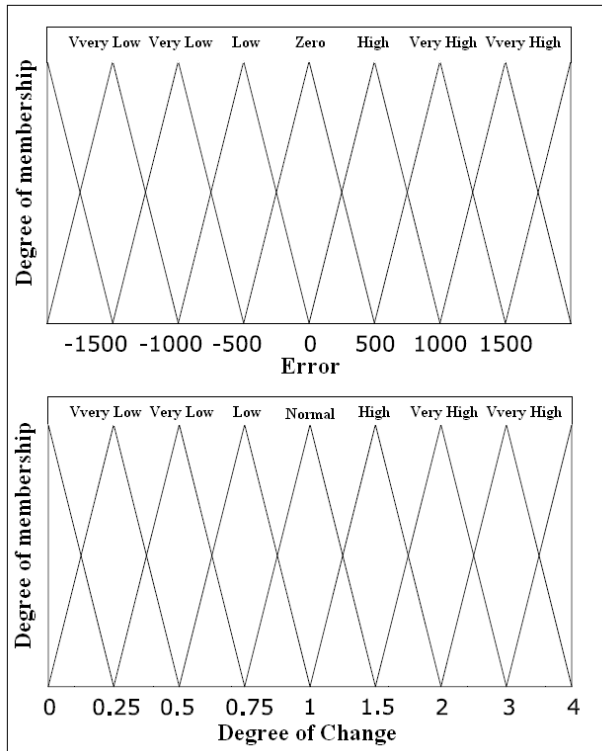

Figure 7. Tuner fuzzy membership functions design

Table II  
TFS RULE BASED SYSTEM

Error	Degree of Change
Vvery Low	Vvery High
Very Low	Very High
Low	High
Zero	Normal
High	Low
Very High	Very Low
Vvery High	Vvery Low

main fuzzy system. In this work, the WAM is applied as a tunable gain to tune the prediction output with a variable weight, which is resulting from the TFS rules. The design of the proposed TFS is presented in this section. The TFS membership functions design is illustrated in Fig 7. The TFS input membership function parameters are set based on the knowledge of the energy demand change in the ECU microgrid. Output membership function parameters are set to assure achieving safe tuning for the prediction model output. The tuning is applied to the subsequent prediction iterations after a feedback signal is supplied through the TFS to tune the prediction results.

The rule based system has also been developed based on the knowledge of the ECU energy demand pattern. Table II shows the rules based system for the proposed TFS.

Finally, the proposed prediction strategy would have the close loop control system characteristics in terms of type of feedback and the control action selection. Figure 8 illustrates

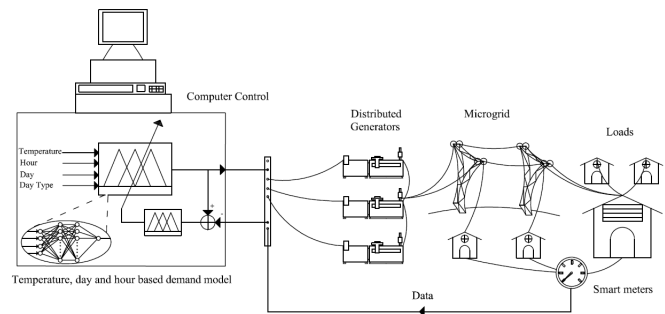

Figure 8. Proposed prediction mechanism

the proposed prediction strategy.

#### IV. RESULTS AND DISCUSSIONS

The proposed prediction mechanism works as a part of the generation scheduling system. Therefore, a safe prediction is required to achieve a reliable generation scheduling. The prediction model helps to economise the amount of generation. Figure 9 illustrates the generation reduction resulting from the prediction model in the economic dispatch.

At certain levels, the model demand prediction is below the real demand. Thus to achieve a secure generation scheduling, it is required to have the model prediction to be always above the actual demand. After analysing ECU energy demand, we have found that it is necessary to add a safety margin to the predicted demand values. Since the maximum observed demand of the ECU microgrid is 2.5 MWh, we have proposed 3 MWh of generation capacity for safe generation planning. In order to ensure a reasonable amount of energy back up during each half-hour interval, 0.5MWh of generation capacity is added to the prediction model. For safety consideration, we will look at the worst prediction accuracy in the model. Figure 9 shows model prediction for the third week of January 2009, which points the weakest prediction accuracy period in January 2009. Attached to the figure, the generation scheduling control strategy using TFS is shown.

To supply ECU with the required amount of energy, it is proposed to install six DGs, each with 0.5 MW generation capacity as shown in Figure 9. To achieve safe DGs rotational usage plan, another 0.5MW DG is proposed. The energy demand has been divided into six zones from our EMS prospective. To insure that every DG has enough stand-by time before it is switched to the operation, the rotational usage plan has been analysed. It has been that under the proposed rotational usage plan, the shortest stand-by time will be 3 hours. Where as in our actual data as shown in Figure 9, the stand-by time is nine hours, which above the needed time to call that type of generators to the operation. Thus it has been theoretically approved that adding another 0.5MW generator to the system can make a successful rotational usage plan for the installed DGs on the ECU microgrid.

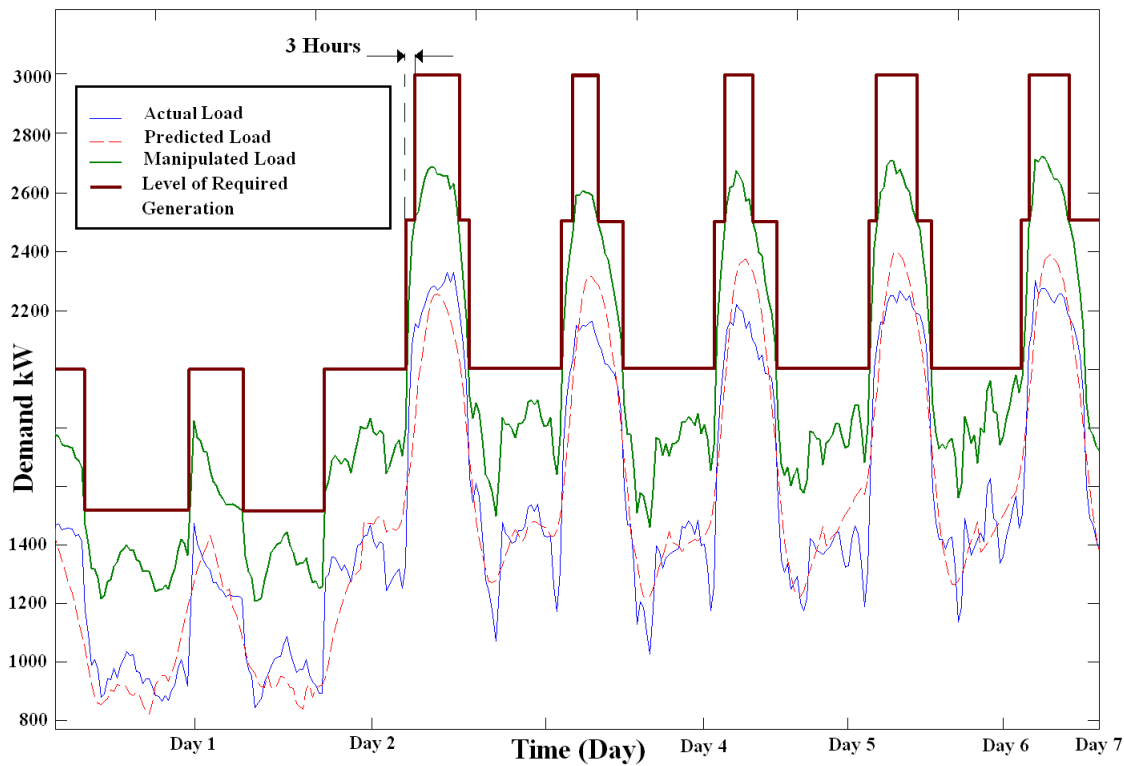

Figure 9. The expected levels of generation reduction using the proposed prediction mechanism

## V. CONCLUSIONS

In this paper, we have modelled energy demand of a microgrid, namely the ECU microgrid. TFS has been added to the prediction model to consider the actual load changes in the prediction results, which facilitates economic dispatch for the ECU microgrid. The TFS has been explained, and the impact of adding it to the prediction model to consider the actual load pattern has been discussed. The demand prediction has been used to determine the number of DGs needed to achieve low cost generation. Simulation studies have shown that the use of TFS in the load model can improve the economic dispatch for the ECU microgrid.

## REFERENCES

- [1] T. Gonen, *Electric Power Distribution System Engineering*. 2<sup>nd</sup> ed., 2008.
- [2] A. Jain, E. Srinivas, and S. K. Kukkadapu, "Fuzzy based day ahead prediction of electric load using mahalanobis distance," in *Power System Technology (POWERCON), 2010 International Conference on*, pp. 1–6.
- [3] U. B. Filik, O. N. Gerek, and M. Kurban, "Hourly forecasting of long term electric energy demand using a novel modeling approach," in *Innovative Computing, Information and Control (ICICIC), 2009 Fourth International Conference on*, pp. 115–118.
- [4] S. A. Villalba and C. A. Bel, "Hybrid demand model for load estimation and short term load forecasting in distribution electric systems," *Power Delivery, IEEE Transactions on*, vol. 15, no. 2, pp. 764–769, 2000.
- [5] M. Y. M.-R. M.-R. A. T. Zohreh Souzanchi-K, Hadi Fanaee-T, "A multi adaptive neuro fuzzy inference system for short term load forecasting by using previous day features," 2010.
- [6] K. Y. Tan and Lun-nong, "Application of adaptive neuro-fuzzy inference system based on data field clustering in load forecasting," 2010.
- [7] M. B. A. M. M. R. A.-F. K. S. Mohammadi, H. Keivani, "Demand forecasting using time series modelling and anfis estimator," 2006.
- [8] F. Pasila, "Multivariate inputs for electrical load forecasting on hybrid neuro-fuzzy and fuzzy c-means forecaster," in *IEEE International Conference on FUZZ SYSTEMS (IEEE World Congress on Computational Intelligence)*, (London, UK), IEEE, 2008.
- [9] H. E. Alireza Khotanzad, Enwang Zhou, "A neuro-fuzzy approach to short-term load forecasting in a price-sensitive environment," *IEEE TRANSACTIONS ON POWER SYSTEMS*, vol. 17, no. 4, p. 10, 2002.
- [10] H. Siahkali and M. Vakilian, "Fuzzy based generation scheduling of power system with large scale wind farms," in *PowerTech, 2009 IEEE Bucharest*, pp. 1–7.
- [11] A. Y. Saber, T. Senjyu, T. Miyagi, N. Urasaki, and T. Funabashi, "Fuzzy unit commitment scheduling using absolutely stochastic simulated annealing," *Power Systems, IEEE Transactions on*, vol. 21, no. 2, pp. 955–964, 2006.
- [12] S. Palamarchuk, "Generation scheduling in the electricity market environment," in *Environment and Electrical Engineering (EEEIC), 2011 10th International Conference on*, pp. 1–4.
- [13] T. Logenthiran and D. Srinivasan, "Short term generation scheduling of a microgrid," in *TENCON 2009 - 2009 IEEE Region 10 Conference*, pp. 1–6.
- [14] L. Ruey-Hsun and L. Jian-Hao, "A fuzzy-optimization approach for generation scheduling with wind and solar energy systems," *Power Systems, IEEE Transactions on*, vol. 22, no. 4, pp. 1665–1674, 2007.
- [15] K. Qian, C. Zhou, M. Allan, and Y. Yuan, "Load modelling in distributed generation planning," in *Sustainable Power Generation and Supply, 2009. SUPERGEN '09. International Conference on*, pp. 1–6.



**T. S. Mahmoud** (M'2011) graduated with a Bachelor of Control Systems Engineering from University of Technology, Iraq, in 2004. He worked in the field of power systems installation in Iraq after his graduation. He obtained his Master in control and automation engineering from Universiti Putra Malaysia, Malaysia, in 2007. He was a lecturer in UCSI University in Kuala Lumpur after that. He is currently pursuing his PhD in the field of energy management systems in Edith Cowan University in Western Australia. His research interests include

control systems design, smart energy systems, SmartGrids, energy management systems and Artificial Intelligence.



**D. Habibi** (M'95, SM'99) graduated with a Bachelor of Engineering (Electrical) with First Class Honours from the University of Tasmania in 1989 and a PhD from the same University in 1994. His employment history includes Telstra Research Laboratories, Flinders University, Intelligent Pixels Inc., and Edith Cowan University, where he is currently a Professor and the Head of the School of Engineering. His research interests include engineering design for sustainable development, reliability and quality of service in communication systems and networks,

smart energy systems, and environmental monitoring technologies. He is a Fellow of Engineers Australia, Electrical College Board member of Engineers Australia, ITEE College Board member of Engineers Australia, Editor-in-Chief of the Australian Journal of Electrical and Electronic Engineering, and Deputy President of the Australian Council of Engineering Deans.



**O. Bass** (M'06, SM'10) was born in Oradea in Romania, on September 30, 1971. He graduated from the "Politehnica" University of Timisoara, Romania, in 1995 and received his PhD from the same University in 2001. His employment history includes research positions at the Budapest University of Technology and Economics, Hong Kong Polytechnic University, Hull University UK, and Utsunomiya University, Japan. He was a lecturer at James Cook University, Queensland, Australia, from 2006 to 2009 and is currently a Senior Lecturer at Edith

Cowan University, Western Australia. His fields of interest include smart grid technologies, renewable energy resources, power electronics, nonlinear dynamics and e-learning. He has co-authored 70 professional publications.



**S. Lachowicz** (M'97, SM'04) was born in Lodz, Poland, on February 22, 1959. He received his MSEE and PhD in Electronic Engineering from the Technical University of Lodz, Poland, in 1981 and 1986 respectively. From 1986 until 1992 he was an assistant professor at the same university. In 1993 he joined School of Engineering at Edith Cowan University, Perth, Western Australia where he is a senior lecturer. He authored and co-authored about 80 scientific publications. His research interests include, smart energy systems, renewable energy sources,

power electronics, and digital systems.