

1-1-2011

Fuzzy Controlled Hydraulic Excavator with Model Parameter Uncertainty

Ganesh Kothapalli
Edith Cowan University

Mohammed Hassan
Edith Cowan University

Follow this and additional works at: <https://ro.ecu.edu.au/ecuworks2011>



Part of the [Mining Engineering Commons](#)

This is an Author's Accepted Manuscript of: Kothapalli, G. , & Hassan, M.Y. (2011). Fuzzy controlled hydraulic excavator with model parameter uncertainty. World Academy of Science, Engineering and Technology, 60, 1889-1894. Available [here](#)

This Journal Article is posted at Research Online.
<https://ro.ecu.edu.au/ecuworks2011/842>

Fuzzy Controlled Hydraulic Excavator with Model Parameter Uncertainty

Ganesh Kothapalli and Mohammed Y. Hassan

Abstract— The hydraulic actuated excavator, being a non-linear mobile machine, encounters many uncertainties. There are uncertainties in the hydraulic system in addition to the uncertain nature of the load. The simulation results obtained in this study show that there is a need for intelligent control of such machines and in particular interval type-2 fuzzy controller is most suitable for minimizing the position error of a typical excavator's bucket under load variations. We consider the model parameter uncertainties such as hydraulic fluid leakage and friction. These are uncertainties which also depend up on the temperature and alter bulk modulus and viscosity of the hydraulic fluid. Such uncertainties together with the load variations cause chattering of the bucket position. The interval type-2 fuzzy controller effectively eliminates the chattering and manages to control the end-effector (bucket) position with positional error in the order of few millimeters.

Keywords— excavator, fuzzy control, hydraulics, mining, type-2.

I. INTRODUCTION

THE hydraulic actuated excavator is a machine used in many industries to increase productivity while handling heavy materials. These machines are better understood by building nonlinear dynamic models that point to many parameters that influence the operation of the hydraulic system. Many such models have been studied [1-4] but none have dealt with the uncertainty that comes about due to disturbances in the hydraulics or the dynamics in load fluctuations. Control of such systems is a challenge and sliding mode control was proposed by Nguyen [5] to overcome the error in position while the bucket of the excavator follows a pre-determined trajectory. This type of control does not provide adequate dynamic response due to severe nonlinearity and uncertainty in the presence of load disturbances. Our studies reveal that an interval type-2 fuzzy (ITF) controller is the right choice for this type of hydraulic machine to deal with the uncertain parameters.

An excavator typically consists of a base and three hydraulic actuated segments; boom, arm and bucket. Each axial segment is actuated by a hydraulic cylinder such that the bucket position can be made to follow any desired trajectory. Although the boom cylinder experiences the maximum load, it is the bucket position accuracy that is important. Hence, we consider the position control of the bucket as our objective.

G. Kothapalli is a Senior Lecturer at the School of Engineering, Edith Cowan University, WA, Australia. (e-mail: g.kothapalli@ecu.edu.au).

M. Y. Hassan is with the Control and Systems Engineering Department, University of Technology, Iraq. He is on leave as an Endeavour Research Fellow with the school of Engineering, Edith Cowan University, WA, Australia. (e-mail: myhazawy@yahoo.com).

The bucket cylinder is a nonlinear device whose performance depends on the bulk modulus of the fluid as well as many frictional components of the hydraulic system. Fig. 1 shows a photo of a typical hydraulic excavator. The hydraulic structures that control the boom and the arm are clearly visible in this photo.



Fig. 1. Photo of a typical excavator used in mining and construction

We used models published in [5] for the hydraulic actuated segments but improvised the model to account for the frictional nonlinearity. We consider bucket cylinder as an electro-hydraulic servo controlled variable fluid actuation device. By controlling the actuation voltage we can vary the output position and thus match the load by the generated pressure. We consider this system as an example of hydraulic position tracking system where the position of the spool valve is controlled by an electrical signal

Hydraulic actuation system can be modelled by taking in to account hydraulic parameters of the three axial segments. It is shown [6] that from the perspective of hydraulic control, the three segments are very similar from modelling perspective and study of the bucket dynamics, for example, provide insights into the other two cylinders as well.

These types of actuators are controlled by conventional controllers during digging operations with limited interaction of soil.

Non-smooth and discontinuous nonlinearities are subjected on the actuator due to saturation in control input, change in the direction of spool of servo's valve friction and valve overlap [2]. In the presence of nonlinearities of the hydraulic actuator, modelled by orifice flow equation, hysteresis of torque motor

electromagnetic characteristics and flow forces of valve [6]-[8]), we need to control the bucket in such a way that the resultant bucket position is error free and robust even when subjected to dynamic load. It should be noted that this hydraulic actuated system experiences parametric and nonlinear uncertainties in the form of bulk modulus of the fluid. One of the natural complex phenomena that exist in all mechanical control systems including hydraulic actuators is friction. These non-idealities lead to error in tracking, limit cycle, oscillation and undesirable stick-slip motion [9]. Another effect that applies external forces to the excavator is the wide variations of soil-tool interaction that are common in any excavator during digging. In all the above mentioned circumstances, a conventional control cannot cope with system dynamics effectively. Another aspect investigated in [10] is automating the excavator during unmanned operations.

Shao [4] developed a hybrid controller composed of a classical PID controller and a Fuzzy controller based on self-adjusting factors. These techniques have the potential to improve both the dynamic and static properties of the system leading to overall robustness.

The unknown and uncertain influence of the external disturbances on the trajectory tracking performance cannot be captured by these linear type traditional controllers.

The ITF controller which is capable of handling nonlinearities and uncertainties in models has the capacity to minimize position error while trajectory tracking. This type of controller was introduced by Mendel in 2001 [11]. The concepts of type-2 sets are extensions of the classical fuzzy sets. A considerable amount of literature has been published on ITF controllers. In 2008, Ozek and Akpolat introduced ITF logic toolbox in MATLAB. It helps users to implement ITF [12]. In another study, a robust adaptive controller of ITF to approximate a class of unknown nonlinear function was proposed by Ougli et al. in 2008. Adaptive laws with Lyapunov's stability analysis were used to adjust the fuzzy parameters online in order to reach the required tracking goal [13]. Intelligent control of robots using ITF logic for the purpose of automation is also discussed in [14], [15]. Results about the tracking performance on different navigation problems were obtained through simulation [14].

The focus of this paper is on the effectiveness of ITF control in capturing two distinct phenomena (variations of bulk modulus and random disturbance due to external load) of hydraulic actuated excavator. Effect of bulk modulus on hydraulic systems is studied by Akkaya [16] and others, and it is found that variations in bulk modulus are akin to variations in applied load on the axial segments of the loader. In these cases there is an uncertainty and controlling the loader's axes becomes difficult. The compelling argument in favor of adapting ITF fuzzy sets comes from the nature of bucket-soil interactions. This unknown nature of soil being dug causes uncertainty in the bucket displacement trajectory [17]. It is well known that ITF fuzzy sets are ideal choice where there are uncertainties [18]. As it is difficult to determine exact nature of soil (sandy, rocky or gravel) in places where an excavator is operating, application of ITF to the control of

bucket is most appropriate. The hydraulic actuated segment has to load the bucket with soil, navigate the bucket over obstacles, unload and return to digging position. It is evident that these activities involve uncertainty.

We account for fluid flow rate of valve and pump hydraulics in our modelling. Although the supply pressure changes dynamically, in our model the supply pressure can be assumed constant since hydraulic servo actuators are used. This assumption can be justified when a hydraulic accumulator that is connected with pressure controlled flow pump is employed [19].

Furthermore, it is well known that temperature and air bubbles in the hydraulic oil can lead to variations in the bulk modulus which, in turn, adds to more uncertainty. To be operable in these uncertainties, we proposed in this paper, an ITF intelligent controller which is discussed in the following section.

II. CONTROLLER DESIGN FOR THE ACTUATOR OF THE BUCKET

One aspect of the construction of conventional fuzzy logic system is the establishment of the rules. Knowledge of building these rules is uncertain, which leads to antecedent or consequents of rules that are uncertain. Consequently, uncertain membership functions (MFs) arise. Thus, this type of control cannot deal with uncertainty.

In type-2 fuzzy set, the membership function (MF) deals with uncertainty with three dimensions. It is the general form of conventional fuzzy logic, which can also be called type-1. It is used when there is a difficulty in obtaining an exact membership function for a set [18]. In order to gain a clear idea about type-2 fuzzy sets and definitions that are used to obtain the results presented in this paper, the reader is referred to the paper by Qugli [13]. Application of fuzzy logic in conjunction with PI control is addressed by Zao [20]. Referring to Fig. 2, the lower and upper membership functions always exist because the domain of the secondary membership function has been constrained in $[0, 1]$. Fig. 2 also shows an example of a sample of type-2 membership function with its secondary memberships.

The structure of the ITF is shown in Fig. 3. It is similar to type-1 ITF but with some differences. The differences are mainly in the nature of the membership functions [18].

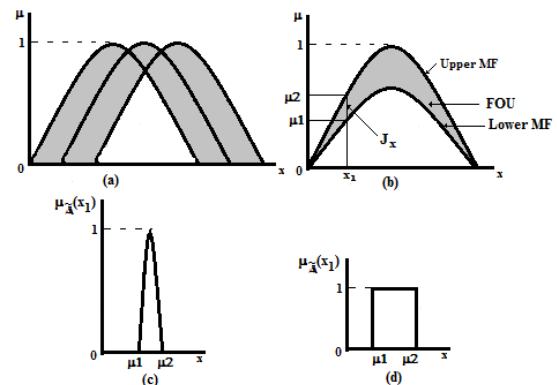

Fig. 2:(a) Type-2 fuzzy set representing type-1 fuzzy set with uncertain mean

(b) Footprint of uncertainty (FOU) for a sample type-2 fuzzy set
(c) The secondary membership function for type-2 fuzzy set

(d) The secondary membership function for Interval of type-2 fuzzy set

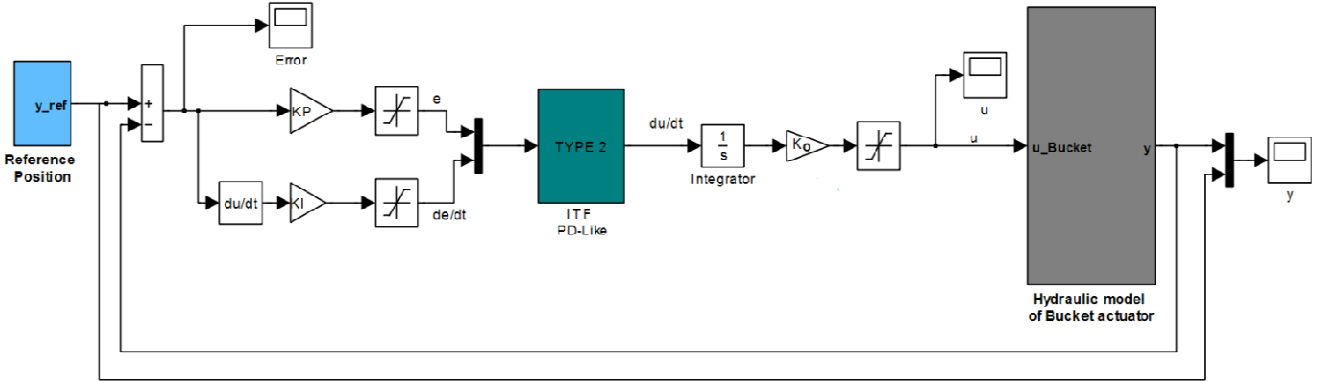

Fig. 3 Interval Type-2 Fuzzy controlled system for the hydraulic actuator of the Bucket

Inputs of ITF are either type-1 singleton or non-singleton. If inputs are modelled as type-2 fuzzy numbers, then it is referred to as a type-2 non-singleton ITF. Defuzzification of ITF consists of two stages. The first stage is to convert type-2 fuzzy set into type-reduced (type-1) fuzzy set using type-reduction operation. Methods used in type-reduction operation include centroid, centre-of-sum, height, modified height and centre-of-sets. Type-1 generated set is defuzzified to generate a crisp value (type-0) using well known techniques that are used in conventional fuzzy control. Calculations of type-reduction operation are very complicated. Therefore, type-2 fuzzy sets are used to make calculations simple. Two types of type-2 exist; Mamdani type and Takagi-Sugeno-Kang (TSK) type. The first type needs type-reduction operation while the second one does not need any type-reduction operation [13]. Detailed information about ITF can be obtained from [18].

The ITF is designed to control the actuator of the bucket segment of robotic excavator. The controller is represented by the following equations [20]:

$$\Delta u(t) = K_p \dot{e}(t) + K_I e(t) \quad (1)$$

where:

$$u(t) = K_o \int \Delta u(t) dt \quad (2)$$

and

$$e(t) = y(t) - y_{ref}(t) \quad (3)$$

The PI controller equation is differentiated (1) to overcome difficulty in formulating rules depending on an integral error because it may have very wide range of universe of discourse [21]. It can be noticed from (1) that the controller needs the error and change of error as inputs where the input gains are K_p and K_I respectively. The output of the equation must be integrated to obtain (2) [21]. K_o is the output scaling factor.

The Simulink block diagram of ITF is type-1-non-singleton and type-2-Mamdani. It is a part of the type-2 fuzzy inference system toolbox that was designed and published by Ozek and Akpolat [12].

III. SIMULATION OF HYDRAULIC ACTUATED EXCAVATOR

The simulation of the excavator together with a ITF is

accomplished by using the model parameters of Komatsu PC05-7 mini excavator retrofitted with hydraulic actuators and associated sensors. This machine has a bucket capacity of $0.05 m^2$, digs up to 3 m height and depth of 2 m, and reaches as far as 3.5 m. The pump can supply the hydraulic actuator up to 18.6 MPa and an accumulator is added to provide a constant combined hydraulic pressure to servo valves. Moog D633 Servo-Proportional Control valves were used to control the flow of oil for each actuator. Permanent-magnet linear force motor is used in these valves to control the position of the spool of valve directly. The control voltage of the valve is within (± 10 V). Single rod and double acting linear actuators are connected with the servo valves to control the motion of excavator links. Details and specification parameters of this model are given in [5].

The parameters of ITF for this type of excavator are selected to have seven type-2 Gaussian membership functions with a normalized universe of discourse (-1, 1) in both the two inputs and the output, as shown in Fig. 4 and Fig. 5 respectively.

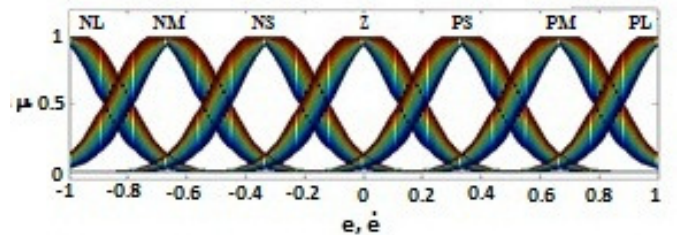

Fig. 4 Membership functions of ITF of e and \dot{e}

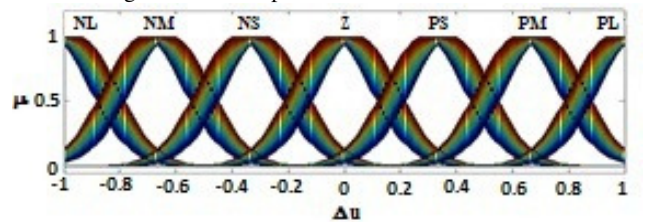

Fig. 5 Membership functions of ITF of Δu

The letters N, Z and P refer to Positive, Zero and Negative

respectively while the letters of L, M and S refer to Large, Medium and Small respectively.

Forty nine rules were selected based on the knowledge of the behaviour of this model as shown in Table 1.

TABLE I
RULE BASE OF THE ITF

\dot{e}	NL	NM	NS	Z	PS	PM	PL
e	NL	NL	NL	NL	NM	NS	Z
NM	NL	NL	NL	NM	NS	Z	PS
NS	NL	NL	NM	NS	Z	PS	PM
Z	NL	NM	NS	Z	PS	PM	PL
PS	NM	NS	Z	PS	PM	PL	PL
PM	NS	Z	PS	PM	PL	PL	PL
PL	Z	PS	PM	PL	PL	PL	PL

Other parameters of this controller were selected as follows: AND operator for minimum operation, OR operator for maximum operation, implication method for minimum operation and aggregation method for maximum operation. Furthermore, Centre of Gravity (CoG) is selected for the type reduction operation and defuzzification.

The response of displacement is affected by the correct selection of the inputs and output scaling factors. The selection can be done using trial and error. Using several trials we obtain the best position response with minimum overshoot, minimum settling time, minimum rise time and minimum steady state error under load and bulk modulus. The scaling factors thus selected for the axis of bucket are: $K_p=30$, $K_I=5$ and $K_o=10$ where K_o holds the absolute value of the maximum servo valve controlled voltage. The sampling time is selected to be 0.002 sec to coincide with the results reported in [5].

The ITF controlled system for the bucket axis is simulated by applying a multilevel trapezoidal shape position trajectory without applied load and nominal bulk modulus ($\beta=100$ MPa), as shown in Fig. 6.

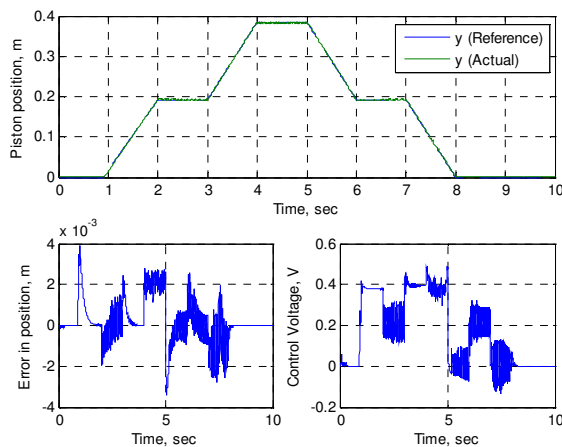

Fig. 6 Responses of actuator position with no load force applied, error in position and control voltage for bucket cylinder of excavator (nominal value of bulk modulus)

It can be observed that the piston moves in complete

synchronization with the multilevel trapezoidal shaped reference trajectory.

A varying load of trapezoid shape in the range of 0 to 2000N (nominal load) is applied upon the actuator of the bucket to study the positional error under varying load. The variation in the load represents the effect of the soil and gravel mix that is dug by the bucket. It is assumed that the bucket experiences increasing and decreasing load forces. The responses of the actuator position, error in position and control voltage for bucket cylinder of the excavator are shown in Fig. 7.

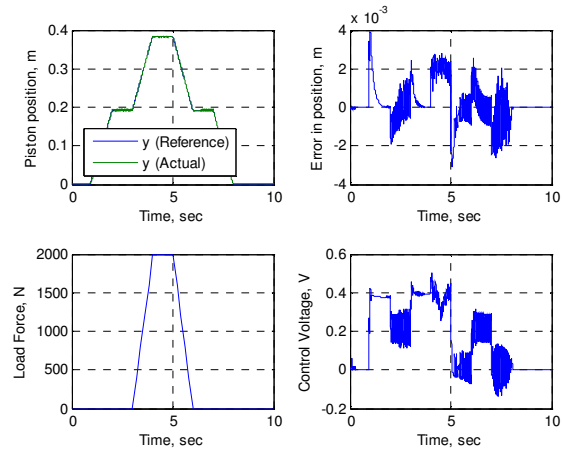

Fig. 7 Responses of actuator position with application of variable load force, error in position and control voltage for bucket cylinder of excavator (using nominal value of bulk modulus)

A nominal bulk modulus is assumed as in previous simulation for comparison purposes. Then the load profile is kept the same (as was the case for the previous simulation shown in Fig. 7) while the bulk modulus is changed to %150 compared to the nominal value. The simulation result is shown in Fig. 8. There is reduced jitter in the positional error. This result confirms that an increase in bulk modulus has the capability to reduce error in position of the bucket while following a pre-defined trajectory.

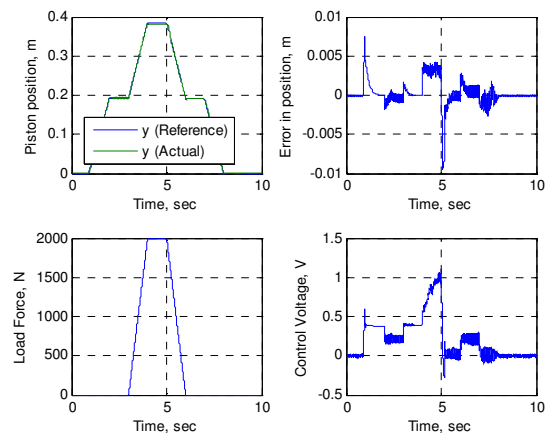

Fig. 8 Responses of actuator position with application of variable load force, error in position and control voltage for bucket cylinder of excavator (using 150% of the nominal value of bulk modulus)

It can be noted from all the previous results that the bucket axis follows the reference position assisted by ITF controller with minimum error in position, minimum overshoot and minimum rise time. We reiterate that this statement can be extended to all three axes of the excavator since the control mechanisms (and their dynamics) are similar.

The controller compensates the effect of the nonlinearities that exist in the model. Also, the controller compensates the effect of varying external force applied to the cylinder of bucket. It can be noted that the voltage of the controller fluctuates in order to compensate the effect of friction that exists at each joint and axis (lower right plots in Figs 6 to 8).

We also simulated the excavator's bucket actuator to study the behavior under reduced bulk modulus while the bucket load is kept the same as before i.e. trapezoidal in shape. As can be observed from Fig. 9 for a pre-defined trapezoidal load force increasing up to 2000 N, the bucket cylinder responds with noticeable jitter in the positional error compared to the previous results. The plots representing the control voltage (lower left plots in Fig. 9) show increased variations while trying to minimize the positional error. Irrespective of the load being identical with other results presented earlier, the bulk modulus being 50% of the nominal value tends to reduce the damping in the system and hence higher demand on the controller's performance. Based on these studies, the authors conclude that ITF has the ability to compensate for both load variations and bulk modulus variations.

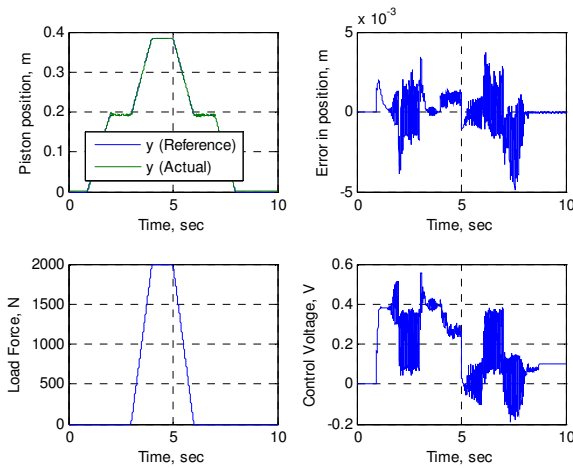

Fig. 9 Responses of actuator position with application of variable load force, error in position and control voltage for bucket cylinder of excavator (using 50% of the nominal value of bulk modulus)

Finally, we show the responses when the bucket experiences unknown and uncertain load variations by adding a uniform noisy load force to a nominal load. A uniform distribution noise with maximum amplitudes of $\pm 10\%$ of the applied nominal load is added to the load to simulate the effects of variations in soil type and all other random uncertainties mentioned before. Fig.10 depicts the results obtained when a random noisy load of maximum values of ± 200 N is added to a step load force of 2000 N.

It is a simulation of uncertain load forces experienced by the bucket when digging in rocky soils.

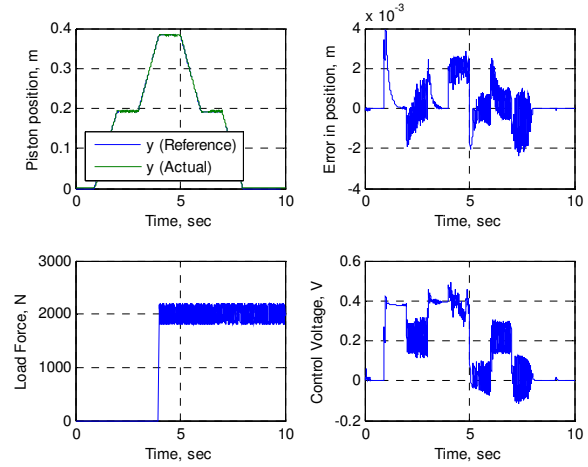

Fig. 10 Responses of actuator position with application of variable and $\pm 10\%$ noisy load force, error in position and control voltage for bucket cylinder of excavator (using nominal value of bulk modulus)

The result shown in Fig.10 confirms our hypothesis that the ITF controller is quite capable of handling both the step change in load force and the additional noisy load due to unknown soil type. To reiterate our stance on the ITF controller's ability, we subjected the actuator to the sever test of reduced bulk modulus of 50% of nominal value while retaining the previous conditions. The responses of actuator position with application of 2000N step plus a $\pm 10\%$ noisy load force with 50% bulk modulus of nominal value are depicted in Fig. 11.

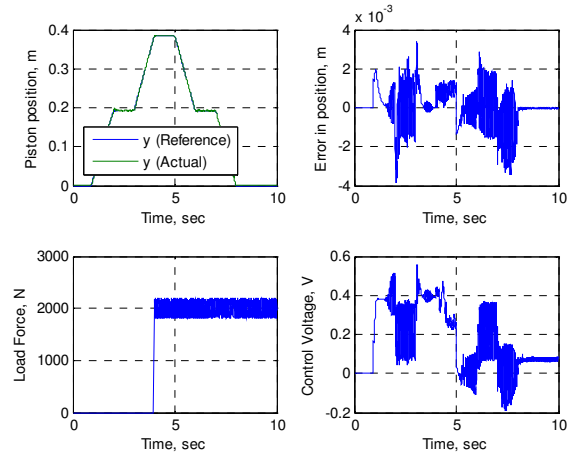

Fig. 11 Responses of actuator position with application of variable and $\pm 10\%$ noisy load force, error in position and control voltage for bucket cylinder of excavator (using 50% of nominal value of bulk modulus)

As can be seen from Fig. 11, the ITF controller succeeds in minimizing the positional error albeit with higher level of jitter in the bucket position.

IV. CONCLUSION

The objectives of studying the effectiveness of ITF in accurately controlling a hydraulic actuated excavator were successfully carried-out. The simulation results yielded positive outcomes that are useful in applying ITF controllers

in various situations. We have included in our simulation, various nonlinearities and simulated one of the three axes of a typical excavator, viz., bucket actuator. Our simulation results indicate that the responses of actuator position error were minimized due to the use of ITF intelligent controller. Our aim was to measure the position error while the bucket follows a pre-defined trajectory (a multilevel trapezoid in our case). We observed higher level of fluctuations in controller voltage as the controller tries to compensate the effects of nonlinear frictional forces and other uncertainties.

This paper dealt with fuzzy assisted intelligent position control of a hydraulically actuated excavator bucket axis. The bucket-soil interactions during digging require intelligent control to overcome undesirable stick-slip motion, limit cycles and oscillations. Our simulations of ITF controller depict advances in control actions compared to other traditional controllers. Presence of disturbances (such as changing bulk modulus and applied load variations) were tackled without significant errors by the ITF controller. Our observed position control response curves show that the jitter in tracking is in the order of less than 5 mm while the bucket is accelerating as well as decelerating.

REFERENCES

- [1] J. Y. Alaydi, "Mathematical modeling for pump controlled system of hydraulic drive unit of single bucket excavator digging mechanism," *Jordan Journal of Mechanical and Industrial Engineering*, vol. 2, no. 3, pp. 157-162, Sep. 2008.
- [2] B. Yao, F. Bu, and G. T. C. Chiu, "Nonlinear adaptive robust control of electro-hydraulic servo system with discontinuous projections," *Proceedings of the 37th IEEE Conference on Decision & Control, USA*, Dec. 1998, pp. 2265-2270.
- [3] S. Tafazoli, C. W. De Dilva, and P. D. Lawrence, "Tracking control of an electrohydraulic manipulator in the presence of friction," *IEEE Transaction on Control Systems Technology*, vol. 6, no. 3, pp. 401-411, May 1998.
- [4] J. Shao, L. Chen, Y. Ji, and Z. Sun, "The Application of fuzzy control strategy in electro-hydraulic servo system," *Proceeding of International Symposium on Communications and Information Technologies (ISCIT2005)*, China, 2005, pp. 159-164.
- [5] H. Q. Nguyen, "Robot low level control of robotic excavation," Ph. D. thesis, University of Sydney, Australia, 2000.
- [6] X. Zong-Yi, G. Qiang, J. Li-Min, and W. Ying-Yin, "Modelling and identification of hydraulic system and its application," *Proceedings of the 17th World Congress: The International Federation of Automatic Control*, Seoul-Korea, July 2008, pp. 6446-6451.
- [7] M. Muvengei and J. Kihui, "Bond graph modelling of mechanical dynamics of an excavator for hydraulic system analysis and design," *International Journal of Mechanical, Industrial and Aerospace Engineering*, vol. 3, no. 4, pp. 248-256, 2009.
- [8] Y. Liu, S. M. Hasan, and H-N. Yul, "Modelling and remote control of an excavator," *International Journal of Automation and Computing*, vol. 7, no. 3, pp. 349-358, Aug. 2010.
- [9] G. Kothapalli and M. Y. Hassan, "Design of a neural network based intelligent PI controller for a pneumatic system," *IAENG International Journal of Computer Science*, vol. 35, no. 2, 2008.
- [10] B. Li, Y. Jun, G. Gang, Z. Yonghua and, L. Wenxing, "High performance control of hydraulic excavator based on fuzzy-PI soft-switch controller," *IEEE International Conference on Computer Science and Automation*, China, June 2011, pp. 676-679.
- [11] J. M. Mendel, *Uncertain rule-based fuzzy logic systems: Introduction and new directions*, NJ: Prentice Hall PTR, 2001.
- [12] M. B. Ozek, and Z. H. Akpolat, "A Software tool: Type-2 fuzzy logic toolbox," *Computer Application in Engineering Education*, 2008, vol. 16, no. 2, pp. 137-146, 2008.
- [13] E. Qugli, I. Lagrat, and I. Boumhidi, "A Type-2 fuzzy adaptive controller of a class of nonlinear system," *International Journal of Computational Intelligence*, vol. 4, no. 4, pp. 282-288, 2008.
- [14] R. Martínez, O. Castillo, and L. T. Aguilar, "Intelligent control for a perturbed autonomous wheeled mobile robot using Type-2 fuzzy logic and genetic algorithm," *Journal of Automation, Mobile Robotics Intelligent Systems*, vol. 2, no. 1, pp. 12-22, 2008.
- [15] Y. S. Chen, and L. Yao, "Robust Type-2 fuzzy control of an automatic guided vehicle for wall-following," *2009 International Conference of Soft Computing and Pattern Recognition*, 2009, pp. 172-177.
- [16] A. V. Akkaya, "Effect of bulk modulus on performance of a hydrostatic transmission control system," *Sadhana*, vol. 31, pp. 543-556, 2006.
- [17] E. G. Nezami, Y. Hashash, D. Zha, and J. Ghaboussi, "Simulation of front end loader bucket-soil interaction using discrete element method," *International Journal for Numerical and Analytical Methods in Geomechanics*, vol. 31, pp. 1147-1162, 2007.
- [18] O. Castillo and P. Melin, *Type-2 fuzzy logic theory and applications*, Berlin: Springer-Verlag, 2008.
- [19] T. Viersm, *Analysis, synthesis and design of hydraulic Servosystems and Pipelines*, Nederland: University of Delft, 2nd Edition, 1990.
- [20] Y. Zao and E. G. Collins, "Fuzzy PI control of weight belt feeder," *IEEE Transaction on Fuzzy Systems*, vol. 11, no. 3, pp. 311-319, June 2003.
- [21] L. Reznik, *Fuzzy Controllers*, Newnes, Australia, 1997.

Ganesh Kothapalli graduated from Bangalore University with a Bachelor of Engineering degree and continued his studies at the University of Alberta and obtained a Master of Science degree. He was awarded a Doctor of Philosophy from the University of New South Wales.

He has been teaching electronics, signal processing applications and control engineering at Edith Cowan University since 1996. He has held academic positions at the University of New South Wales and Monash University prior to joining ECU. While at Monash (1991-1995) he has worked on the applications of Artificial Neural Networks. He was an active member of the Electronic Design Automation Centre and taught courses in the areas of large-scale system simulation using EDA tools and system design techniques for building robust systems. He has also taught courses covering digital system design using standard cell, gate array and programmable logic arrays. He taught post-graduate courses in mixed analog-digital system design during 2001 at the University of Ulm, Germany while on visiting professorship.

He has also published papers on the optimal estimation of parameters and modelling of intelligent systems.

Mohammed Y. Hassan (B.Sc. 89 in electrical and electronics engineering, M.Sc. 95 in control engineering, and Ph. D. 2003 in control engineering and automation from the university of technology). He is working as an assistant professor in the control and systems engineering department, university of technology in Iraq. He taught courses in the areas of Adaptive control, Microcontrollers, Engineering Designs, Electrical Circuits, Electronics, Intelligent systems, Computer Control for undergraduate and postgraduate students. Also, he supervised several M. Sc. theses.

He has several research publications in journals and conference proceedings. His areas of research interest are in Intelligent Control, Adaptive control, Modeling, Fuzzy logic, Neural network, Genetic Algorithm, Microcomputers and Microcontrollers.

Dr. Hassan has received in 2007 and 2011 two Endeavour postdoctoral research Fellowship awards from the department of Education, Employments and Workplace Relations (DEEWR) in the government of Australia to do researches in the school of Engineering, Edith Cowan University in West Australia.